

General Specifications

Models UT130, UT150/UT152/UT155 Temperature Controllers



GS 05C01E02-01E

General

UT100 series temperature controllers provide only the functions and size you require for your application. 1/16, 1/8 and 1/4 DIN sizes are available. Easy-to-read displays show input and the setpoint. T/C or RTD inputs are standard and the output type is selectable: ON/OFF, voltage pulse or DC current. The controllers operate in an Automatic mode only. Optional alarm contact outputs, retransmission output, contact input setpoint selection and RS485 communication are available. Each features dynamic self-tuning function for easy start up. Super Control fuzzy logic for overshoot suppression is a proven champion.

Model and Suffix Codes

Model	Suffix code	Description
UT130		Temperature controller
Control output for standard type (or for heating)	-R	Relay output (time-proportional PID or on/off control)
	-V	Voltage pulse output (time-proportional PID)
Control output for cooling	N	No cooling output (standard type)
	R	Relay output (time-proportional PID or on/off control)
	V	Voltage pulse output (time-proportional PID)
Option	/AL	Alarm outputs (2 points) (Note1)
	/HBA	Heater disconnection alarm (includes optional /AL function) (Note1) (Note2)
	/RS	Communication function (Note2) (Note3)
	/V24	Power Supply 24V DC / 24V AC

Note1:/AL option cannot be specified when /HBA option is specified. /HBA option already includes the /AL option.

Note2:/HBA option cannot be specified at the same time.

Note3:When specifying the /RS option, be sure to order the required number of copies of Communication Functions Instruction Manual separately. You will not be supplied and instruction manual just because you order for the /RS option.

Model	Suffix code	Description
UT150 UT152 UT155		Temperature controller
Control output for standard-type (or for heating)	-R	Relay output (time-proportional PID or on/off control)
	-V	Voltage pulse output (time-proportional PID)
Control output for cooling	N	No cooling output (standard type)
	R	Relay output (time-proportional PID or on/off control)
	V	Voltage pulse output (time-proportional PID)
Option	/AL	Alarm outputs (2 points) (Note2)
	/HBA	Heater disconnection alarm (includes optional /AL function) (Note1) (Note2) (Note3)
	/EX	SP1/SP2 switching, starting of timer, and RUN/STOP switching by external contacts (Note4)
	/RET	PV retransmission output in 4 to 20mA (Note3)
	/RS	Communication function (Note4) (Note5)
	/V24	Power Supply 24V DC / 24V AC

Note1:/HBA option cannot be specified when 4 to 20 mA output (heating-side) is specified.

Note2:/AL option cannot be specified when /HBA option is specified.

/HBA option already includes the /AL option.

Note3:/HBA option and /RET option cannot be specified at the same time.

Note4:/EX option and /RS option cannot be specified at the same time (model UT150 only)

Note5:/EX option includes contact input 1 (for switching between the SP1 and SP2 target setpoints using external contacts) and contact input 2 (for enabling the timer).

Note6:When specifying the /RS option, be sure to order the required number of copies of Communication Functions Instruction Manual separately. You will not be supplied and instruction manual just because you order for the /RS option.



Measured Value Input

The UT100 series allows you to freely change the input type by software.

Table 1. UT130 Measured Input Ranges

Input Type	Range(°C)	Range Code	Range(°F)	Range Code	
Thermocouple	K	1	-199 to 999°F	31	
		2	32 to 999°F	32	
		3	32 to 750°F	33	
		4	-199 to 400°F	34	
	J	-199 to 999°C	5	-199 to 999°F	35
	T	-199 to 400°C	6	-199 to 750°F	36
	E	-199 to 999°C	7	-199 to 999°F	37
	L	-199 to 900°C	12	-199 to 999°F	42
	U	-199 to 400°C	13	-199 to 750°F	43
	RTD	Pt100	15	-199 to 999°F	45
16			32 to 750°F	46	
		17	-199 to 400°F	47	
		18	-199 to 999°F	48	
JPt100		19			

Table 2. UT150/152/155 Measured Input Ranges

Input Type	Range(°C)	Range Code(°C)	Range(°F)	Range Code(°F)	
Thermocouple	K	1	-300 to 2500°F	31	
		2	32.0 to 999.9°F	32	
		3	32.0 to 750.0°F	33	
		4	-300.0 to 400.0°F	34	
	J	-199.9 to 999.9°C	5	-300.0 to 2100°F	35
	T	-199.9 to 400.0°C	6	-300.0 to 750.0°F	36
	E	-199.9 to 999.9°C	7	-300.0 to 1800.0°F	37
	R	0 to 1700°C	8	32 to 3100°F	38
	S	0 to 1700°C	9	32 to 3100°F	39
	B	0 to 1800°C	10	32 to 3200°F	40
	N	-200 to 1300°C	11	-300 to 2400°F	41
	L	-199.9 to 900.0°C	12	-300 to 1600°F	42
	U	-199.9 to 400.0°C	13	-300 to 750°F	43
	RTD	Platinel 2	14	32 to 2500°F	44
			15	-199.9 to 999.9°F	45
		Pt100	16	32.0 to 750.0°F	46
			17	-300 to 400°F	47
			18	-199.9 to 999.9°F	48
		JPt100	19		
DC voltage		0 to 100mV	20		
	0 to 5 V	21			
	1 to 5 V	22			
	0 to 10 V	23			

Note: Scalling is enable in the following 4 range.
-1999 to 9999, -199.9 to 999.9, -199.99 to 99.99, -1.999 to 9.999

Hardware Specifications

Measured Value (PV) Input

Input: 1 point
Input type: Universal; can be selected by soft ware
Input accuracy (at 23±2°C ambient temperature)
 • Thermocouple: ±2°C
 However,
 • ±4°C for thermocouple input-200 to -100°C
 • ±3°C for thermocouple input-100 to 0°C
 • ±5°C for type R and S (±9°C for 0 to 500°C)
 • ±9°C for type B (accuracy is not guaranteed for 0 to 400°C)
 • RTD: ±1°C ±1digit
 • Voltage(mV, V)±0.3%

Sampling period for measured value input: 500 ms
Burn-out detection: Functions for thermocouple or RTD input (burn-out upscale only; can not be switched off)

Input resistance:
 1 MΩ or greater for thermocouple or DC mV input
 Approx. 1 MΩ for DC V input
Maximum allowable signal source resistance:
 250 Ω for thermocouple or DC mV input 2 kΩ for DC V input
 Effect of signal source's resistance: Less than whichever is greater, ±0.2 μV/1Ω or ±0.01% / 100Ω

Maximum allowable wiring resistance for RTD input:
 10 Ω/wire (The resistance values of three wires must be the same.)
 Effect of wiring resistance: ±0.2°C / 10Ω maximum

Allowable input voltage:
 ±10 V DC for thermocouple or DC mV input
 ±20 V DC for DC V input

Noise rejection ratio (50/60Hz)
 Normal mode noise: Min. 40 dB
 Common mode noise: Min. 120 dB
 (Min. 90 dB for DC V input)

Error of reference junction compensation:
 ±1.5°C (at 15-35°C)
 ±2.0°C (at 0-50°C)
 The reference junction compensation cannot be switched off.

Applicable Standards:
 Thermocouple and resistance temperature detector JIS/IEC/DIN (ITS90)

Response time: 2 second or less, 63% (10 - 90%)
 (The time required for transmission output to reach 63% of the maximum excursion when PV abruptly changes from 10% to 90%)

Control Output

Output: 1 point (for standard type) or 2 points (for heating/cooling type)

Output type:
 Choose one from (1) to (3) below:
 (1) Relay contact output
 Contact capacity: 3 A at 240 V AC or 3 A at 30 V DC (with resistance load)

Note: The control output relay cannot be replaced by users

(2) Voltage pulse output
 On voltage: 12 to 18 V DC
 Off voltage: 0.1 V DC or less
 load resistance: 600 Ω or greater
 short-circuit current: approx. 30 mA

(3) Current output
 Output signal: 4 to 20 mA
 Maximum load resistance: 600 Ω
 Output accuracy: ±0.3% of span (at 23 ±2°C ambient temperature)

Display

Measured value and setpoint display:
 [UT150/UT152/UT155]
 4-digit, 7-segment LED display

[UT130]
 3-digit, 7-segment LED display
 Switches between SP and PV display.

Character height: See the table below.

	UT130	UT150	UT152	UT155
PV display (mm)	17.5	13.5	13.5	20.0
SP display (mm)	N/A	9.0	9.0	9.5

Status indicator lamps: LEDs

Retransmission Output

The retransmission output is provided only when the /RET option is specified, but is not available for the UT130 or a heating/cooling type.

Output signal: PV(measured value) in 4 to 20 mA DC
Maximum load resistance: 600 Ω
Output accuracy: ±0.3% of span (at 23 ±2°C ambient temperature)

Contact Inputs

The contact inputs are provided only when the /EX option is specified, but are not available for the UT130.

Functions:
 (1) Switching over two setpoints (SP1 and SP2)
 (2) Starting a timer(See the following "Alarm Functions.")
 (3) RUN/STOP switching

Specify two functions from the three functions using parameter DIS.

Input: 2 points (with the shared common terminal)
Input type: Non-voltage contact or transistor contact input

Contact capacity: At least 12 V, 10 mA
On/off judgment: On state for 1kΩ or less;
 Off state for 20 kΩ or greater

Alarm Functions

Alarm Functions (Option Code /AL or /HBA)
Alarm types: 22 types (Waiting action can be set by software):

PVhigh limit, PV low limit, Deviation high limit, Deviation low limit, De-energized on deviation high limit, De-energized on deviation low limit, Deviation high and low limits, High and low limits within deviation, De-energized on PV high limit, De-energized on PV low limit, self-diagnostic alarm, FAIL output

Alarm output: 2 relay contacts
 Relay contact capacity: 1 A at 240 V AC or 1 A at 30 V DC (with resistance load)

Heater Disconnection Alarm Function (Option Code /HBA)
 The heater disconnection alarm is available when time-proportional PID control or on/off control is selected.

Heater current setting range: 1 to 80 A
Alarm output: 1 relay contact (The terminals are the same as those of the /AL option.)

On time of burn-out detection: Min. 0.2 second
Sensor: CTL-6-S-H or CTL-12-S36-8 (URD Co. Ltd.)
 To be purchased separately.

Timer Function (Option Code /EX/AL or /EX/HBA)
 The output contact status changes when the preset time has passed since "TMR" contact turned on. The contact action can be selected by software from:

(1) Make contact - the contact closes upon time-up.
 (2) Break - the contact opens upon time-up.

Input contact type: See "Contact Inputs" above.

Communication Function

The communication function is provided only when the /RS option is specified.

Communication Protocol
Personal computer link: Used for communication with a personal computer, or UT link module of the FA-M3 controller (from Yokogawa Electric Corporation).

Ladder communication: Used for communication with a ladder communication module of the FA-M3, or a programmable controller of other manufacturers.

MODBUS communication: Used for communication with equipment featuring the MODBUS protocol.

Communication Interface

Applicable standards: Complies with EIA RS-485
Number of controllers that can be connected: Up to 31

Maximum communication distance: 1,200 m
Communication method: Two-wire half-duplex, start-stop synchronization, non-procedural

Baud rate: 2400, 4800, or 9600 bps

Safety and EMC Standards

Safety:
 Compliant with IEC/EN61010-1 (CE), approved by C22.2 No.61010-1, approved by UL508.

Installation category: CAT II Pollution degree: 2 (IEC/EN 61010-1, C22.2 No.61010-1)

Measurement category: I (CAT I: IEC/EN61010-1) Rated measurement input voltage: 10V DC max. (across terminals), 300 V AC max. (across ground)

Rated transient overvoltage: 1500 V (Note)
 Note: It is a value on the safety standard which is assumed by IEC/EN61010-1 in measurement category I, and is not the value which guarantees an apparatus performance.

EMC standards: Complies with EN61326, EN61000-3-2, EN61000-3-3 and EN55011 (CE). Class A Group 1.

All wires except those for the power supply and relay contact output terminals are shielded.

During test, the controller continues to operate with the measurement accuracy within ±20% of the range.

Construction, Mounting, and Wiring

Construction: Dust-proof and Drip-proof front panel conforming to IP65 [Models UT130/UT150] and IP55 [Models UT152/UT155].

For side-by-side close installation, the controller loses its drip-proof protection.

Casing: ABS resin and polycarbonate
Case color: Black

Mounting: Flush panel mounting
Terminals: Screw terminals

External dimensions: Refer to P.3.
Weight: UT130/150: Approx. 200g
 UT152 : Approx. 300g
 UT155 : Approx. 400g

Panel cutout dimensions: Refer to P.4.

Power Supply and Isolation

Power Supply (Common for All Models)

Power supply	Voltage	Rated at 100-240 V AC 24 V AC/DC when "/V24" is specified
	Frequency	50 or 60 Hz
Maximum power consumption		8 VA maximum(4W maximum) when "/V24" is specified : 3W maximum
Memory		Non-volatile memory
Withstanding voltage	Between primary terminals and secondary terminals (See Notes 1 and 3.)	1500 V AC for 1 minute (Note 2)
Insulation resistance	Between primary terminals and secondary terminals (See Notes 1 and 3.)	20M Ω or more at 500 V DC

Note 1 : The primary terminals are the power supply terminals and relay output terminals. The secondary terminals are the analog input and output terminals, the voltage pulse output terminals, and the contact input terminals.
 Note 2 : The withstanding voltage is specified as 2300 V AC per minute to provide a margin of safety.
 Note 3 : 24V power supply is the secondary terminal.

Isolation
 The bold lines below indicate reinforced isolation, and the broken line indicates functional isolation.

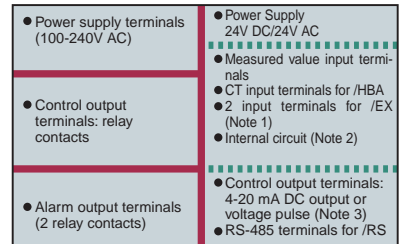

Note 1: The /EX option is not available for the UT130.
 Note 2: Neither the measured value input terminals, CT input terminals for the /HBA option, nor input terminals for the /EX option are isolated from the internal circuit.
 Note 3: The UT130 does not have the 4 to 20 mA DC output.

Environmental Conditions

Normal Operating Conditions
Warm-up time: At least 30 minutes
Ambient temperature: 0 to 50°C (0 to 40°C when mounted side-by-side)

Rate of change of temperature: 10°C/h or less
Ambient humidity: 20 to 90% RH (no condensation allowed)

Magnetic field: 400 A/m or less
Continuous vibrations of 5 to 14 Hz: Amplitude of 1.2 mm or less

Continuous vibrations of 14 to 150 Hz: 4.9 m/s² (0.5G) or less

Short-period vibrations: 14.7 m/s² (1.5G) for 15 seconds or less

Shock: 98 m/s² (10G) for 11 milliseconds or less
Mounting angle: Upward incline of up to 30 degrees; downward incline is not allowed.

Altitude: 2000m or less above sea level

Maximum Effects from Operating Conditions
 (1) Temperature effects

Thermocouple, DC mV and DC V input: ±2 μV/°C or ±0.02% of F.S./°C, whichever is the larger
Resistance temperature detector: ±0.05°C/°C or less

Analog output: ±0.05% of F.S./°C

(2) Effect from fluctuation of power supply voltage (within rated voltage range)
Analog input: ±0.2 μV/V or ±0.002% of F.S./V, whichever is the larger
Analog output: ±0.05% of F.S./V

Transportation and Storage Conditions
Temperature: -25 to 70°C
Humidity: 5 to 95% RH (no condensation allowed)

Shock: Package drop height 90 cm (when packed in the dedicated package)

Function Block Diagram

In this block diagram of a UT100 series controller, the shaded area functions are featured in all the UT100 series controllers including the UT130; the white area functions are featured in the UT150, UT152, and UT155 controllers only.

When ordering, please specify the model, suffix, and option codes according to the functions required.

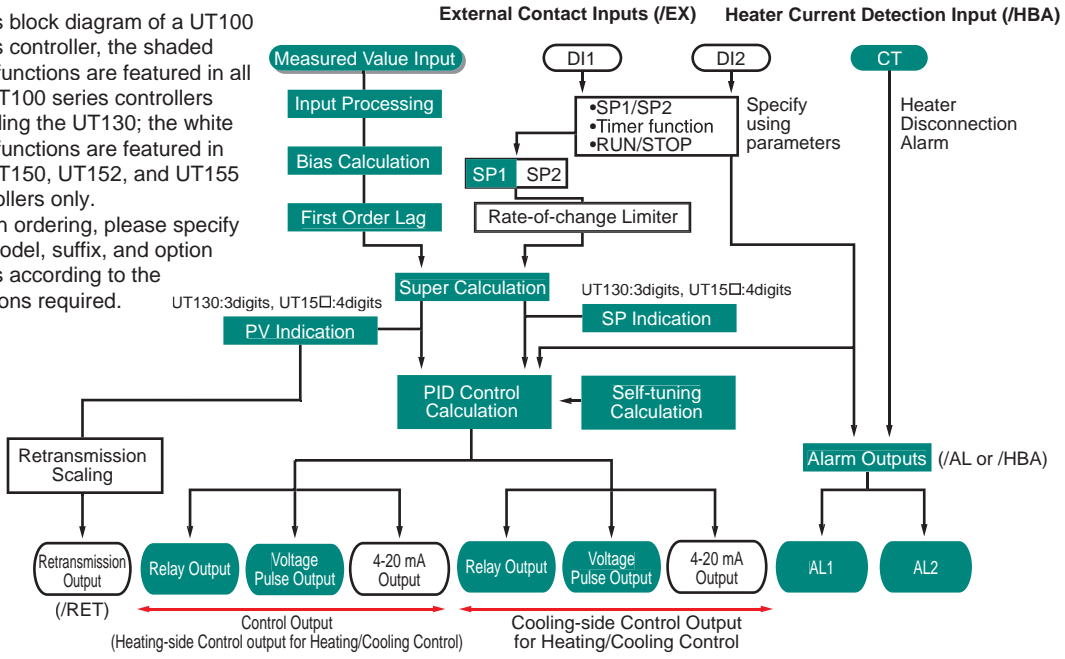

External Dimensions

● UT130

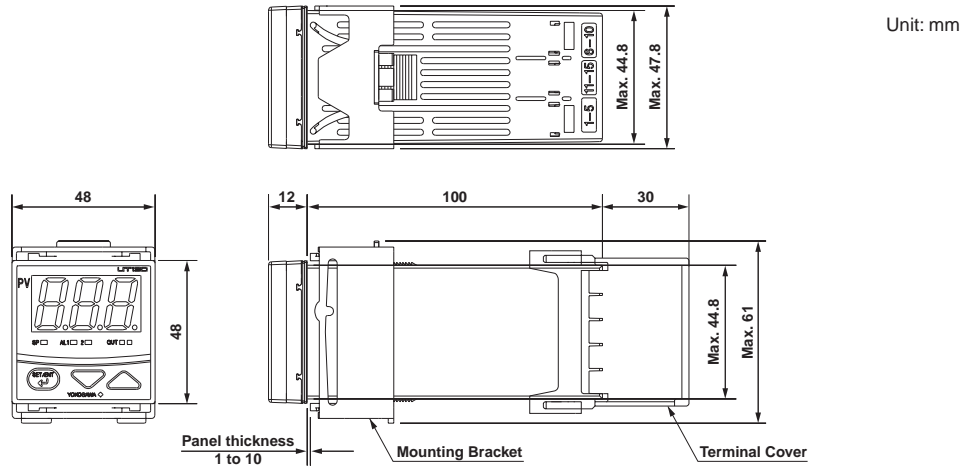

● UT150

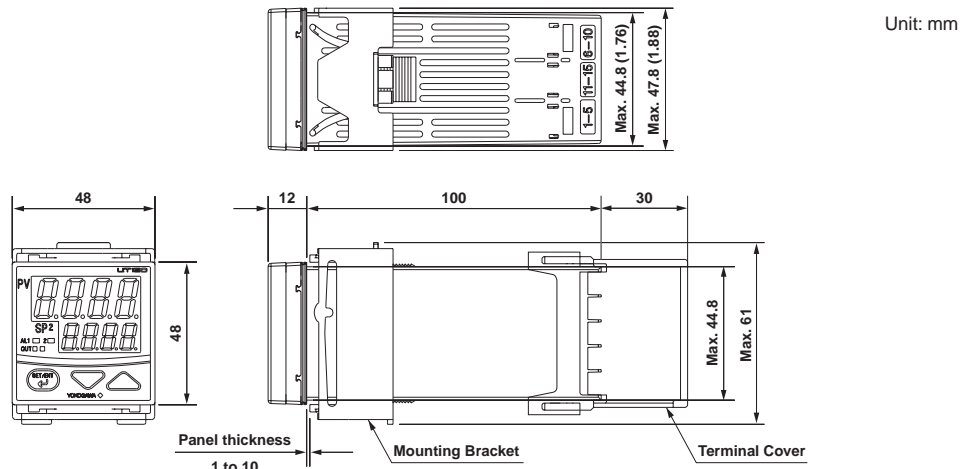

Normal Allowable Deviation=± (Value of JIS B 0401-1999 tolerance grade IT18) /2

External Dimensions

●UT152

Unit: mm

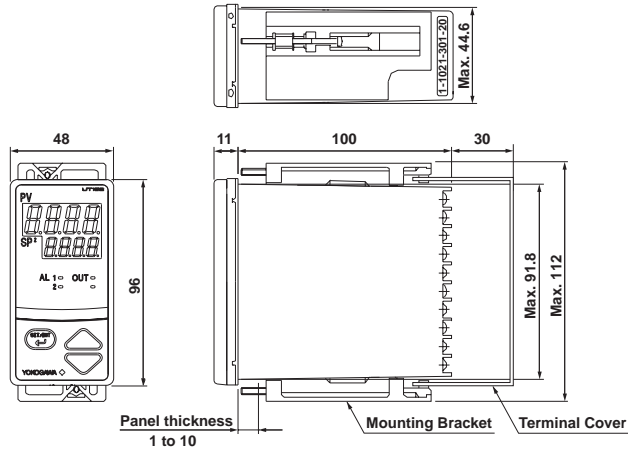

●UT155

Unit: mm

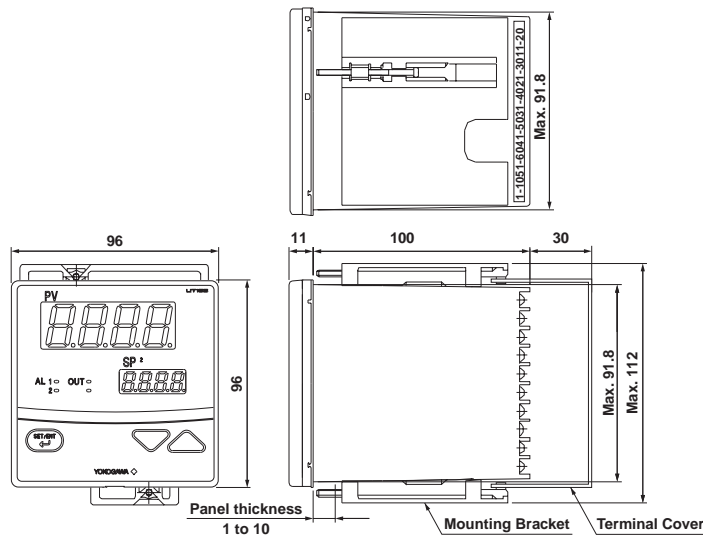

Normal Allowable Deviation=± (Value of JIS B 0401-1999 tolerance grade IT18) /2

Panel Cutout Dimensions

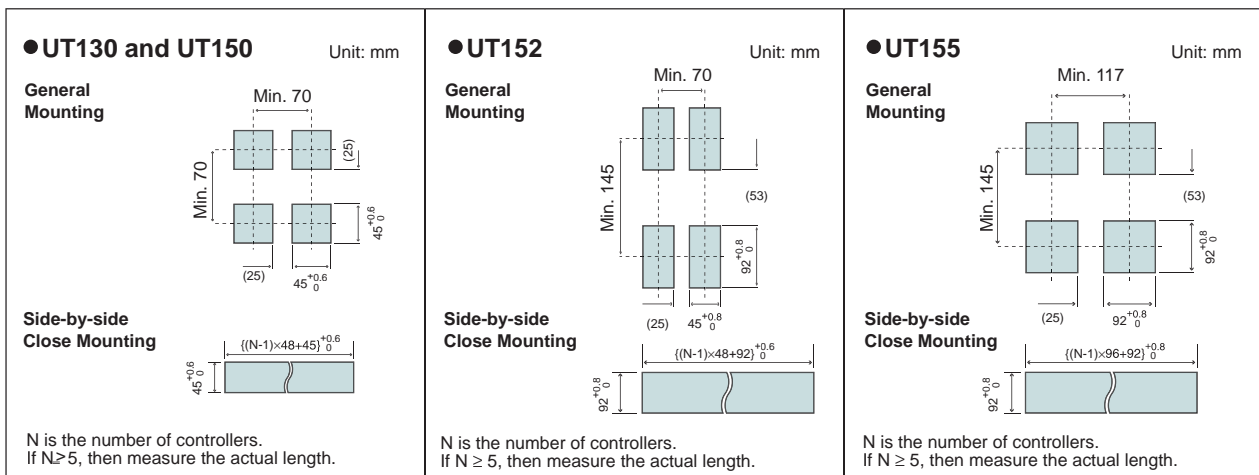

UT130 Terminal Arrangement

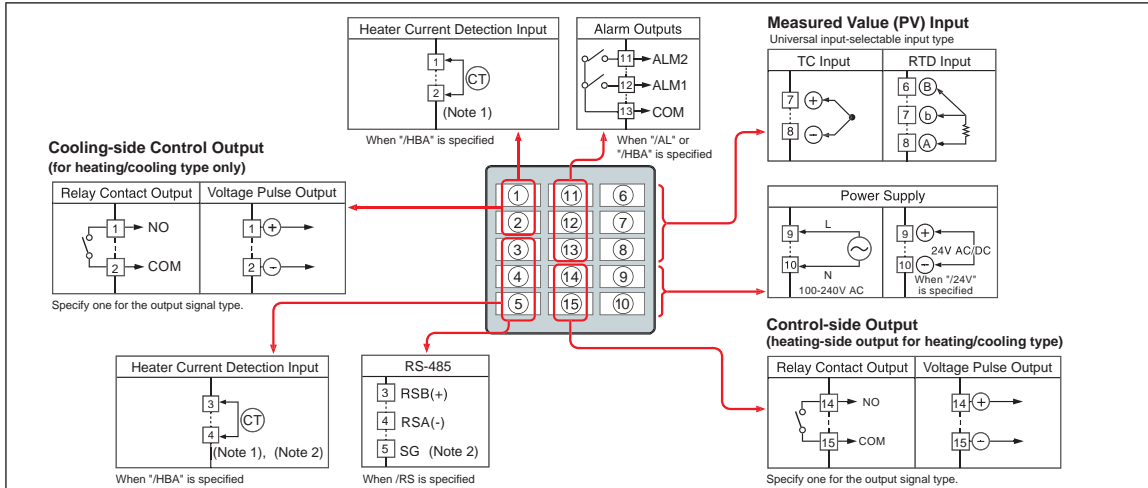

Note 1: The heater current detection input terminals (option code:/HBA) are defined as terminals 1 and 2 for a standard type and as terminals 3 and 4 for a heating/cooling type.
Note 2: For a heating/cooling model, you are not allowed to specify both the /HBA and /RS options at the same time.

UT150 Terminal Arrangement

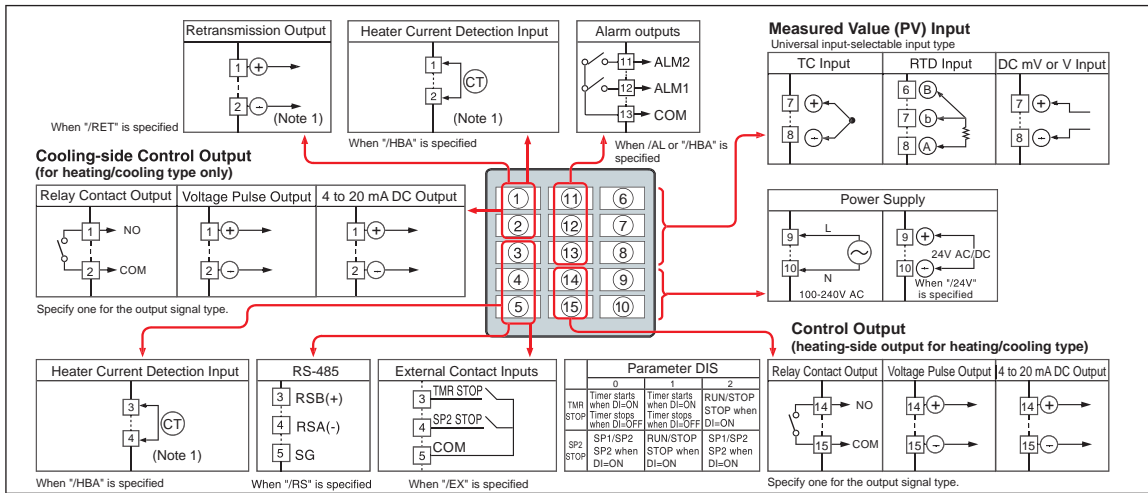

Note 1: The heater current detection input terminals (option code:/HBA) are defined as terminals 1 and 2 for a standard model, and as terminals 3 and 4 for a heating/cooling model. When the /RET option is specified, these terminals are defined as terminals 3 and 4.

UT152/UT155 Terminal Arrangement

